



Quantum Leap for the Virtualized Data Center

New products from Emulex, VMware and Intel provide maximum costs savings and enhanced performance for server virtualization

At a Glance

Challenging economic conditions are driving requirements to optimize performance and reduce costs, and server virtualization has become a game-changing technology to achieve these objectives.

New products from Emulex, VMware and Intel are delivering the scalability and performance needed to maximize virtualization ratios and minimize costs per VM. By combining these technologies into a scalable virtualized server platform, data centers can enjoy increased performance and agility with substantial costs savings.

The key components to implement next-generation server virtualization are:

- VMware vSphere 4
- Emulex LightPulse 8Gb/s Host Bus Adapters (HBAs)
- Intel Xeon processor 5500 series

This tech brief highlights each of these technologies.

A quantum leap is defined as an abrupt change or a dramatic advance. With challenging economic conditions and tight budgets, IT organizations are looking for a quantum leap in technology that will boost performance and reduce costs in the data center. New products from Emulex®, VMware® and Intel® are delivering that quantum leap by delivering game-changing improvements in scalability and performance for virtualized servers.

Server virtualization has been accepted as a critical technology to optimize the data center. The next-generation synergistic components that maximize virtualization ratios are:

- VMware vSphere® 4
- Emulex LightPulse® 8Gb/s Host Bus Adapters (HBAs)
- Intel Xeon® processor 5500 series

By combining these products into a scalable virtualized server platform, data centers can enjoy increased performance and agility with substantial cost savings. This tech brief highlights each of these technologies.

VMware vSphere 4

VMware vSphere 4 is a new suite of products from VMware that enables data centers to deliver computing resources in an agile, cost-effective way and provides the infrastructure needed to implement cloud computing. VMware vSphere 4 is built on the ESX/ESXi 4.0 operating system and provides a comprehensive suite of products to optimize and manage the VMware virtualization environment.

ESX/ESXi 4.0 delivers the increased capacity needed to fully leverage the benefits of high-performance servers and adapters. Key features include:

- 64-bit VMkernel and VMware Service Console
- Host systems scalable to 64 cores, 1 TB of RAM and 512 virtual CPUs
- Guests scalable to 255 GB of RAM and 8 virtual CPUs
- Optimized storage stack

Quantum Leap for the Virtualized Data Center

For applications requiring maximum I/O rates, VMDirectPath is introduced in ESX/ESXi 4.0 as an experimental feature. VMDirectPath provides direct access from a guest OS to a dedicated I/O port using Virtualization Technology for Directed I/O (VT-d), which is supported with the Intel Xeon processor 5500 series and Emulex LightPulse 8Gb/s HBAs. A protected subset of the host's physical memory is used for direct memory access (DMA) and interrupt processing for the guest OS, eliminating the overhead of device emulation.

VMware vSphere 4 also includes many new management features that optimize resource usage and save costs for power and cooling.

Emulex LightPulse 8Gb/s HBAs Near Bare-Metal Performance for VMware vSphere 4

With maximum I/O rates for vSphere 4 that are an impressive 98% of non-virtualized environments, Emulex LightPulse Fibre Channel HBAs deliver performance for virtualized servers that is nearly equal to bare metal servers. Throughput is now at full line rate for full duplex at 8Gb/s. This high throughput feature better addresses the I/O demands of data archival, data warehousing, and streaming environments.

Next Generation Emulex Products Deliver Enhanced Performance for the Enterprise

Steeped in a rich heritage of enterprise-class design, the LPe12000 family is available in single-port, dual-port, quad-port and blade configurations, delivering 8Gb/s throughput per channel, doubling the speed of the previous 4Gb/s families. This increase in bandwidth is especially critical for virtualized servers with HBA ports that are shared across many applications.

Emulex adapters and drivers are also designed to leverage the enhanced storage stack in ESX/ESXi 4.0. Tests done in the Emulex performance lab with ESX 4.0 and the LPe12000 showed a 200% increase in I/O transactions per second (IOPs) and CPU efficiency (IOPs per unit of CPU usage) when compared to ESX 3.5. With larger block sizes, it's possible to reach the full bandwidth of 8Gb/s.

IOPs with Typical Block Sizes

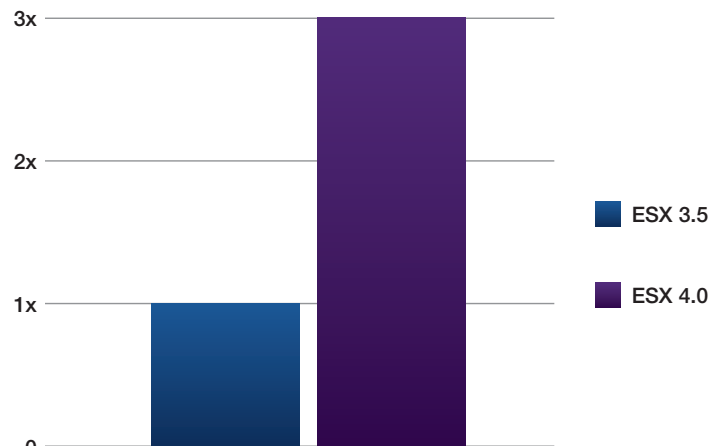

Figure 1 Emulex 8Gb/s HBAs provide 3x IOPs with VMware vSphere 4.

Cost savings of a different type can be achieved with the Emulex OneConnect™ Universal Converged Network Adapter (UCNA) family, which are multi-protocol adapters that offload TCP/IP networking protocols plus Fibre Channel over Ethernet (FCoE) or iSCSI storage protocols over 10Gb/s Ethernet. The payoff is simplified cabling and reduced costs with a single adapter, cable and switch port for SAN and LAN traffic.

Other key features for the combination of Emulex adapters and VMware vSphere 4 include:

- **Online management**—With the release of VMware vSphere 4, an Emulex common interface model (CIM) provider is included with the ESX/ESXi 4.0 distribution. The CIM provider communicates with a CIM client in the Emulex HBAnyware® and OneCommand™ Manager management applications to provide first-time online adapter management for ESXi 4.0 servers. HBAnyware and OneCommand Manager can also be used to manage Emulex adapters on servers running ESX 3.5, ESX 4.0 and other mainstream operating systems, with management done throughout the network from a single console.
- **NPIV**—N_Port ID Virtualization (NPIV) allows a physical adapter port to be logged in to a Fibre Channel fabric switch with multiple identities. Virtual machines (VMs) and virtual ports (VPorts) are created with VMware vCenter and each VPort is given a virtual worldwide port name (WWPN) address. This allows VMs to have a unique identity on the SAN and enables VM-level support for key SAN management features that include zoning, LUN masking, storage chargeback, backup and quality of service (QoS).

Quantum Leap for the Virtualized Data Center

Intel Xeon Processor 5500 Series

The Intel Xeon processor 5500 series combines new processor and platform architectures with new memory and I/O subsystems to provide a quantum-level improvement in performance and energy efficiency.

The Intel Xeon processor 5500 series supports up to 2 sockets and introduces the Intel QuickPath Interface (QPI) technology shown in Figure 2. A follow-on Xeon release will scale to 4 sockets.

Each processor has 4 cores and a dedicated memory controller that can access up to 9 slots of local DDR3 memory. Serial QPI links provide high-speed connections between processors and external memory, and between processors and the I/O hub. Optimum performance is achieved when the processor can use cache and interrupt contexts in local memory. Dedicated memory in other processors can be accessed as needed, using high-speed QPI connections.

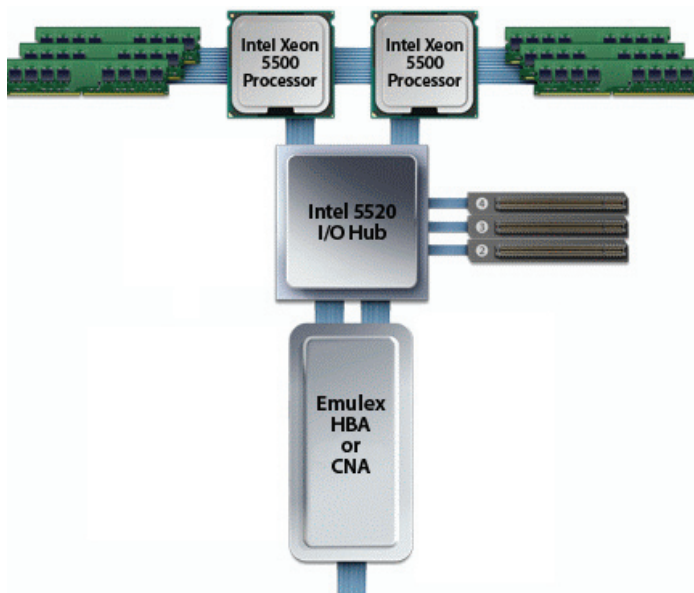

Figure 2 Intel QuickPath Interface.

Conclusion

The synergy of VMware vSphere 4, Emulex LightPulse 8Gb/s HBAs, OneConnect UCNAs and the Intel Xeon processor 5500 series drives the justification to replace single-core, single-function systems with high-performance virtualized servers. The alignment of these new technologies maximizes the number of VMs per server and minimizes the cost per VM. The bottom line is savings for power, cooling, maintenance and IT management that make a compelling case for a next-generation upgrade.



World Headquarters 3333 Susan Street, Costa Mesa, CA 92626 +1 714 662 5600
Wokingham, UK +44 (0) 118 977 2929 | **Munich, Germany** +49 (0) 89 97007 177
Paris, France +33 (0) 158 580 022 | **Beijing, China** +86 10 68499547
Tokyo, Japan +81 3 5322 1348 | **Bangalore, India** +91 80 40156789

Connect with Emulex

twitter.com/emulex [friendfeed.com/emulex](https://www.facebook.com/emulex) bit.ly/emulexlinks bit.ly/emulexfb

www.emulex.com

©2009 Emulex, Inc. All rights reserved. This document refers to various companies and products by their trade names. In most, if not all cases, their respective companies claim these designations as trademarks or registered trademarks. This information is provided for reference only. Although this information is believed to be accurate and reliable at the time of publication, Emulex assumes no responsibility for errors or omissions. Emulex reserves the right to make changes or corrections without notice. This report is the property of Emulex and may not be duplicated without permission from the Company.