

# Emulex IOP 502M and Emulex IOC 500S Multi-application, Completely Flexible SAS I/O Controllers

## AT A GLANCE

This paper discusses two new SAS-based products and how they can make storage system providers' jobs easier by enabling multi-application designs for next-generation external storage arrays.

## PRODUCTS

Emulex IOP 502M, Emulex IOC 500S

## APPLICATIONS

FC/SAS and SAS/SAS External Storage Arrays

## Introduction

Serial Attached SCSI (SAS) has been making in-roads into the server storage market for the last year—which is all part of the natural evolution for storage since SAS was designed as the replacement technology for SCSI. However, now, as we are seeing SAS deployments begin to advance into external storage systems, it becomes all that much more important for storage system providers to consider the full cost of ownership for the products they are deploying. Not only is the on-going cost of goods an important factor to consider, but ease of deployment, and overall flexibility in system design are other factors that should be kept in mind.

This white paper discusses two new SAS-based products—the Emulex IOP 502M and the Emulex IOC 500S—and how they can make storage system providers' jobs easier by enabling multi-application designs for next-generation external storage arrays.

## Emulex SAS I/O Controller Family: Multiple Products with One Design

Based on the same silicon, the Emulex IOP 502M and the Emulex IOC 500S are members of a driver-compatible, multi-protocol IOC product family. Designed for storage system providers that want flexibility in their storage controllers, the IOP 502M and the IOC 500S are compatible with Emulex's Service Level Interface (SLI™) technology, which allows storage system providers to leverage driver-compatible designs across many different applications and protocols to reduce development efforts and time to market.

Both the IOP 502M and the IOC 500S architectures were co-developed by Emulex and Intel to provide storage system providers with both high performance and flexibility for a wide range of storage applications. The robust feature set of the products ensures interoperability and ease-of-design for data communications between servers, switches, and external storage systems. The state-of-the-art integration within the product family minimizes cost overhead and, at the same time, reduces the total board space and power requirements for emerging embedded solutions.

The IOP 502M and the IOC 500S offers storage system provides the ability to scale to more than 2,000 drives in a single system. The IOP 502M and IOC 500S also provide data security through the support of BlockGuard®. BlockGuard is an Emulex-designed block data integrity (based on the ANSI T10 DIF standard), which provides enhanced reliable delivery of data across storage networks for end-to-end data protection.

Additionally, the use of SLI automatically allows any port on the IOP 502M or the IOC 500S to operate in either target mode or initiator mode—allowing for front-end connections on the storage array, or cache coherency operations on the back-end of the array.

Figure 1—Emulex IOP 502M / IOC 500S Block Diagram

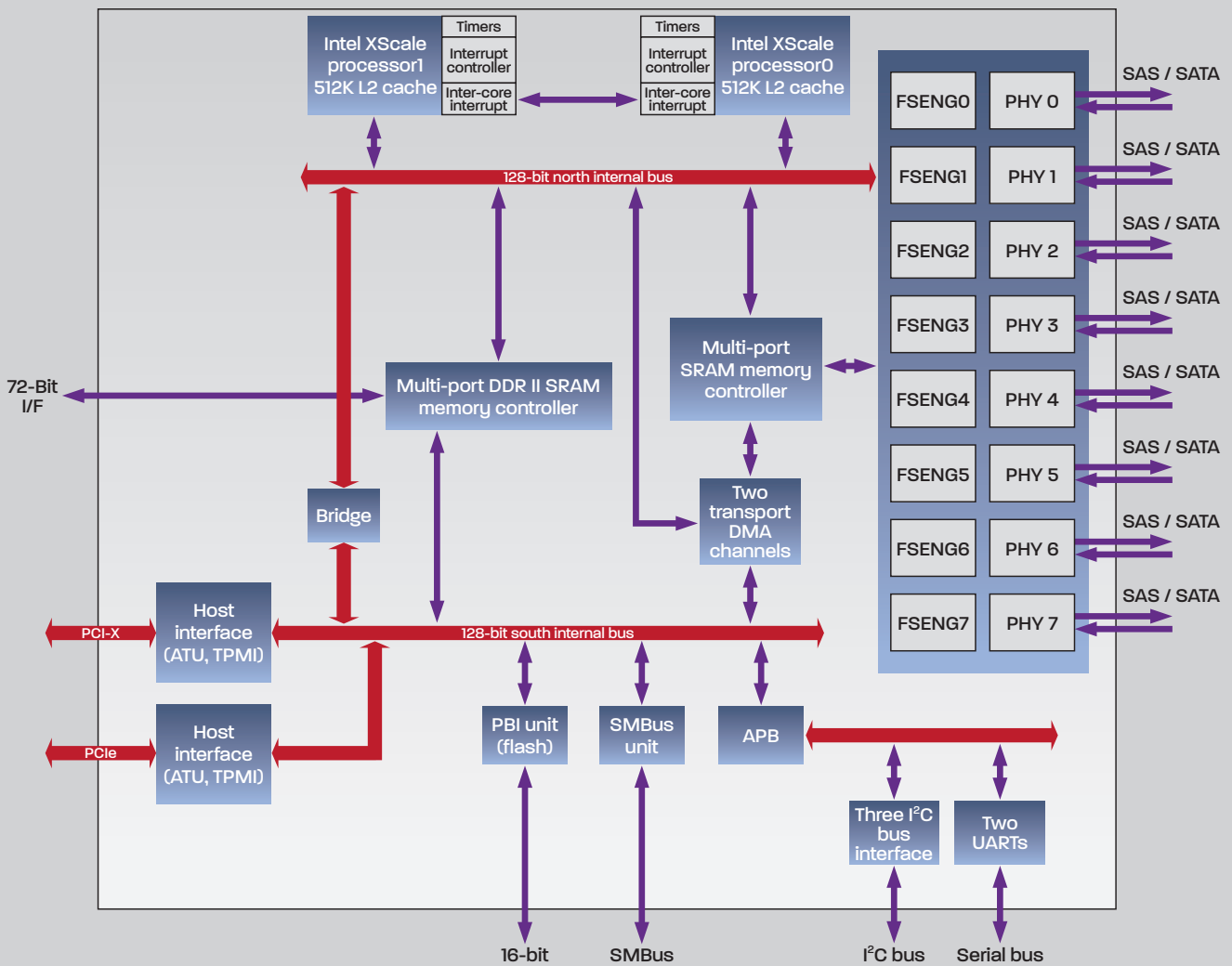

### Emulex SLI Technology: Delivering Software Level Flexibility

Recognizing the benefits flexibility and stability provide from a common, consistent architecture, Emulex established in 1995 a standard interface between the host-based software components of its Fibre Channel architecture and the hardware and firmware elements resident in its ASIC-based hardware solutions. This interface is called the Service Level Interface (SLI) technology.

Since its inception, Emulex's SLI technology has been carried forward across all generations of Emulex's host bus adapter (HBA) products. In addition to these advances, Emulex's SLI technology has now been updated to enable driver compatibility across multiple protocols (e.g. FC and SAS). This enhanced driver compatibility allows storage system providers to write drivers for FC and SAS/SATA while sharing a common architecture—requiring only protocol differences in the driver. As a result, approximately 80-85% of the driver is common between FC and SAS/SATA-based systems. Additionally, Emulex's SLI technology allows firmware to be upgraded independently of drivers, providing an increased return on investment and investment protection.

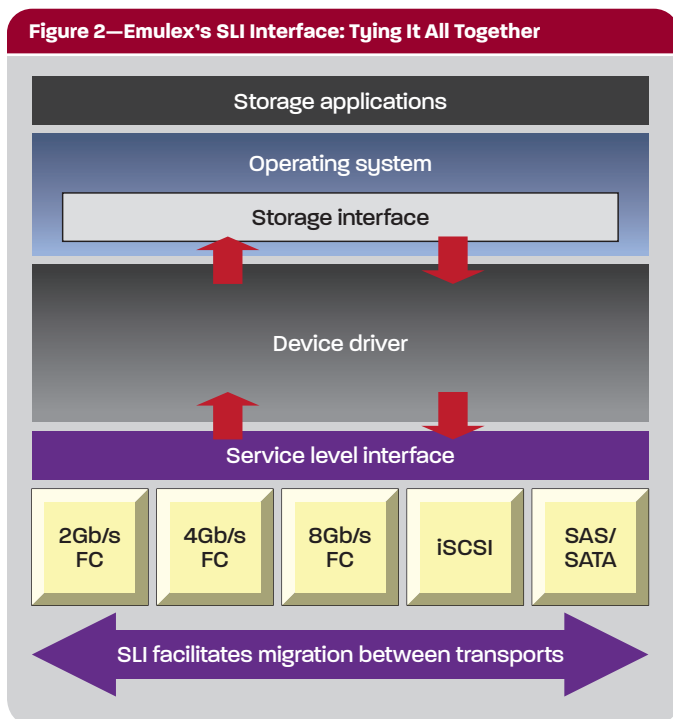

### Applications

The Emulex IOP 502M and the IOC 500S are high-performance SAS solutions designed for external storage solutions that are both pin- and driver-compatible with the latest generation of storage products from Intel and Emulex—resulting in maximized design savings and time-to-market advantages for storage system providers. The IOP 502M can be configured for FC/SAS IOP functionality, while the integrated I/O Processor in the IOP 502M can be utilized by any OEM application (such as RAID) in order to create a cost-effective single-chip FC/SAS RAID solution. The IOC 500S is configured such that both the integrated Intel XScale™ processors are utilized for protocol—allowing for the highest performance solution in the product family. Both products have the ability to have any port simultaneously operate as target and initiator. This allows the storage system providers flexibility in their storage controller interface designs.

These capabilities offer storage system providers a wide range of opportunities to consider when designing their storage arrays. Some application examples that benefit from the multi-protocol embedded storage topology provided by the IOP 502M and the IOC 500S include (Figures 3 and 4):

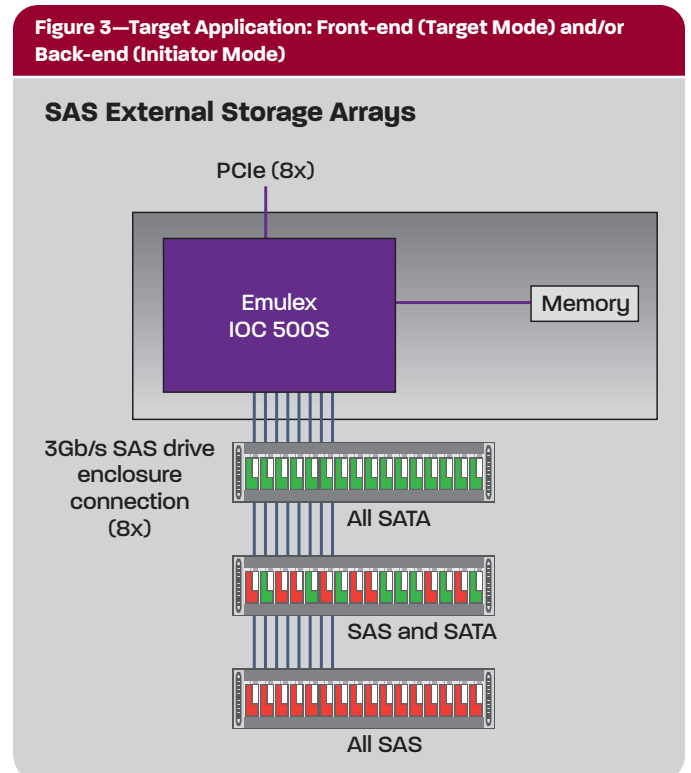

**Figure 4—Target Application: Front-end (Target Mode) and Back-end (Initiator Mode) Plus RAID on Integrated Intel XScale Processor**

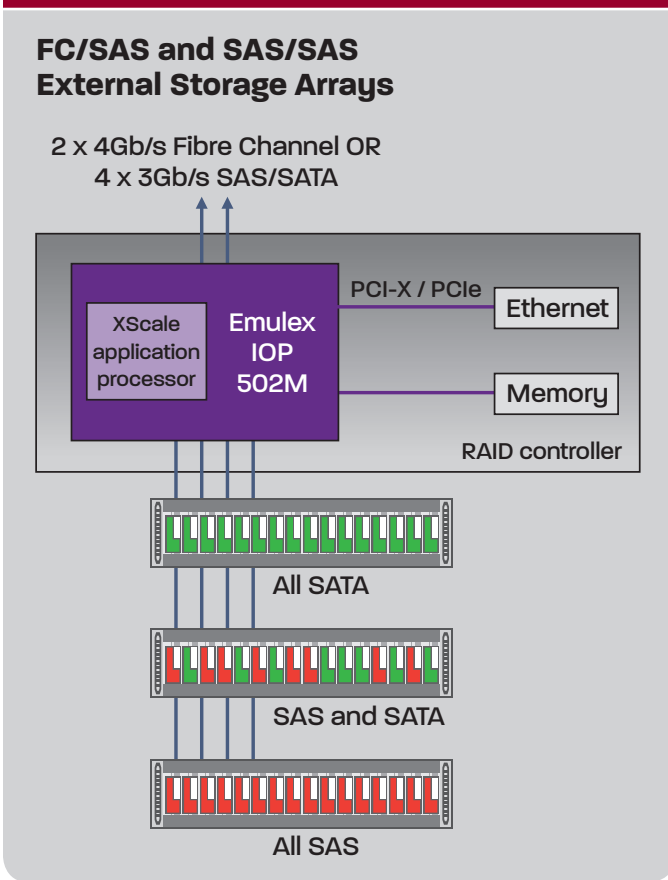

In Figure 3, the Emulex IOC 500S is being utilized on the back-end of the storage array—interfacing via the PCIe bus to the array processor. Ports can be configured for either x2, x4 or x8 wide ports. In the x2 configuration, the usage model could interface to another Emulex IOC 500S in order to provide cache coherency over the SAS connections. The IOC 500S can be connected directly to a SAS drive, SATA drive, or via a SAS Expander.

In Figure 4, the Emulex IOP 502M is shown as a single-chip solution for a front-end FC connection—integrated RAID on the I/O Processor with SAS connections to the back-end of the array. As in the usage model for the IOC 500S, the SAS ports can be configured in either a x2 or x4 wide port with direct connection to either a SAS drive, SATA drive, SAS Expander, or another IOP 502M for cache coherency.

### Conclusion

There are many important factors for storage system providers to consider when developing their server storage designs, and these decisions are only compounded when applied to designs for external storage arrays. It is critical that capabilities like pin- and driver-compatibility, simultaneous SAS target and initiator functions, and overall design flexibility are taken into consideration when evaluating the design and time-to-market savings for new storage arrays. The Emulex IOP 502M and Emulex IOC 500S provide these capabilities, and give storage system providers the required flexibility to meet the needs of their next generation external storage system designs.

For additional information on the Emulex IOP 502M and the Emulex IOC 500S, please visit:

#### Emulex Embedded Storage Solutions Web Page

<http://www.emulex.com/solutions/embedded/index.jsp>

#### Emulex IOP 502M Web Page

<http://www.emulex.com/products/embeddedioc-iop/502m/ds.jsp>

#### Emulex IOP 502M Data Sheet

<http://www.emulex.com/products/embeddedioc-iop/502m/ds.pdf>

#### Emulex IOC 500S Web Page

<http://www.emulex.com/products/embeddedioc-iop/500s/ds.jsp>

#### Emulex IOC 500S Data Sheet

<http://www.emulex.com/products/embeddedioc-iop/500s/ds.pdf>

This document refers to various companies and products by their trade names. In most, if not all cases, their respective companies claim these designations as trademarks or registered trademarks. This information is provided for reference only. Although this information is believed to be accurate and reliable at the time of publication, Emulex assumes no responsibility for errors or omissions. Emulex reserves the right to make changes or corrections without notice. This report is the property of Emulex Corporation and may not be duplicated without permission from the Company.

08-424-10/07