



Solution  
Implementer's  
Series™

Deployment Guide

# Deploying 8Gb/s Fibre Channel with BladeSystem and VMware vSphere

Create robust, highly-  
available VMware  
environments with best-of-  
breed Fibre Channel storage  
networking and HP blades



vmware®

EMULEX®



## Table of contents

Emulex Solution Implementer's series .....	3
Executive summary .....	3
Introduction.....	4
Selecting solution components.....	4
Emulex LPe1205-HP HBA (HP Part Number 456972-B21).....	5
HP c-Class BladeSystem c3000 enclosure.....	5
I/O interconnect modules .....	6
HP ProLiant BL460c G7 server blade.....	7
HP StorageWorks EVA.....	7
Solution deployment overview .....	7
Deploying solution hardware.....	8
Ensuring interoperability .....	9
Updating firmware.....	10
Configuring the BladeSystem enclosure.....	10
Mapping Fibre Channel connections.....	10
Configuring the BladeSystem domain.....	12
Completing the configuration .....	14
Zoning for VMware .....	15
Booting from SAN .....	15
Configuring boot from SAN .....	16
Installing ESX .....	17
Installation methods.....	17
Performing the installation.....	18
Managing the solution.....	18
Key functionality .....	18
Installing OneCommand Manager.....	20
Summary .....	21
Appendix A – The Emulex LPe1250-HP 8Gb/s Fibre Channel mezzanine card.....	22
Key features .....	22
Key benefits .....	22
Installing a mezzanine card.....	23
Appendix B – Determining the firmware levels of HP components.....	24
Onboard Administrator.....	24
8Gb/s Virtual Connect FC module .....	25
1/10Gb/s Virtual Connect Ethernet module.....	26
BL460c G7 server blade.....	27
For more information .....	28



## Emulex Solution Implementer's series

This document is part of the Emulex Solution Implementer's Series, which provides IT administrators and system architects (implementers) with solution and deployment information on popular server and software platforms. As the leader in I/O adapters – Fibre Channel, Ethernet, iSCSI and Fibre Channel over Ethernet (FCoE) – Emulex's technology team wants to help provide best practices for implementing I/O for the increasingly complex virtualization, database, and other mission-critical solutions.

### Executive summary

Virtualized workloads are essential in every data center's goals of IT consolidation, agility, and business alignment. To maximize flexibility in this environment, virtual machines (VMs) are typically configured on shared Fibre Channel, allowing VMs to be booted over the network and moved (migrated) between host servers to fulfill capacity, availability or maintenance requirements. 8Gb/s Fibre Channel is now the best practice for such storage networking use cases and overall VM density and service levels. Indeed, with 8Gb/s HBAs, a VM with local storage.

Scalability is another key concern in today's data center. In response, Emulex has developed 8Gb/s Fibre Channel adapters that can reduce the complexity involved in implementing and configuring a virtualized environment on a Fibre Channel SAN.

Emulex has worked closely with HP from the design stage onwards to qualify I/O adapters for use with BladeSystem and HP StorageWorks arrays, thus creating a best-of-breed I/O solution that can scale to four<sup>1</sup> physical 8Gb/s Fibre Channel connections per blade or 64 in a single BladeSystem enclosure<sup>2</sup>, enabling dozens of VMs. The intent of the whitepaper is to assist those who will deploy for the first time an HP c-Class BladeSystem blade server with 8Gb/s Fibre Channel. In addition, it will also demonstrate the tight integration between Emulex I/O adapters, HP c-Class BladeSystem and HP StorageWorks infrastructure, while exploring some of the capabilities of a typical adapter. This use case includes the VMware® vSphere platform, which extends virtualization to the server-edge, making it easier to consolidate and scale resources in a virtualized environment.

**Target audience:** This implementer's guide is intended for server administrators, storage administrators, VMware administrators, network administrators, system and sales engineers, application engineers and other technical users of ProLiant server blades, BladeSystem infrastructure and HP Virtual Connect (VC) technology.

---

<sup>1</sup> For the HP ProLiant BL460c G7 server blade

<sup>2</sup> For the BladeSystem c7000 enclosure



## Introduction

This document outlines a baseline configuration based on certified, tested HP c-Class BladeSystem and HP StorageWorks EVA hardware that can be used to create a robust, highly-available ESX environment featuring 8Gb/s Fibre Channel adapters and storage.

## Selecting solution components

This section provides guidelines for selecting components for the baseline 8Gb/s Fibre Channel solution. Key components include:

- Emulex LightPulse® LPe1205-HP 8Gb/s Fibre Channel mezzanine card (HP Part Number 456972-B21)
- HP c-Class BladeSystem c3000 enclosure
- HP Virtual Connect I/O interconnect modules
- HP ProLiant BL460c G7 server blade
- HP StorageWorks Enterprise Virtual Array (EVA)

HP products add value to this solution in the following areas:

- Stability
- Business continuity
- High availability
- Manageability
- Backup/recovery

All of the HP c-Class BladeSystem and HP StorageWorks components used in the configuration have been tested and certified by both HP and VMware.

Overviews of these solution components are provided below.



## Emulex LPe1205-HP HBA (HP Part Number 456972-B21)

ESX hosts typically attach to Fibre Channel SANs using a mix of 4Gb/s and 8Gb/s initiators. However, as x86 servers become faster, with bigger memory capacity and new Flash memory caching and storage tiering options, VM consolidation ratios are increasing. At the same time, more I/O intensive workloads like databases are increasingly virtualized, requiring richer quality of service. In order to meet these I/O demands, it is necessary to migrate to 8Gb/s Fibre Channel, providing a larger data pipe to support the growing VM ratios and quality of service (QoS), and to better accommodate large-block, sequential I/O workloads.

The Emulex LPe1205-HP HBA<sup>3</sup> (HP part number 456972-B21) is a high-performance mezzanine card that delivers Fibre Channel connectivity via a direct connection to the system board of a late-generation HP ProLiant server blade. The HBA is equipped with two 8Gb/s Fibre Channel ports and has been built with the most demanding enterprises in mind. In addition to outstanding, field-proven reliability, these adapters offer advanced management capabilities via Emulex's OneCommand™ Manager application, with its enterprise-class scalability and easy-to-use, time-saving features.

Deployment with VMware ESX is simple since drivers for the HBA are in-box. There is a single driver for all Emulex adapter models; thus, although each adapter has separate firmware and driver components, you do not need to reboot the server after installing firmware upgrades, discovering newly provisioned targets and LUNs or making persistent binding changes.

On-board support for N\_Port ID Virtualization (NPIV)<sup>4</sup> allows you to virtualize the data path between VM and SAN storage. Now, up to 128 VMs<sup>5</sup> running on the same host server can access separate storage resources; moreover, storage provisioned to a VM is no longer tied to a physical adapter.

For more information on this HBA, refer to [Appendix A – The Emulex LPe1250-HP 8Gb/s Fibre Channel mezzanine card](#).

## HP c-Class BladeSystem c3000 enclosure

HP c-Class [BladeSystem](#) delivers an entire infrastructure in a single enclosure, thus reducing your overall costs and simplifying the building, management and maintenance of a multi-server environment. The HP c-Class [BladeSystem c3000 enclosure](#) provides device bays that can support up to eight half-height ProLiant c-Class server blades. External connectivity is provided via I/O interconnect bays that support a range of I/O interconnect modules for Ethernet, Fibre Channel, FCoE, iSCSI and more.

---

<sup>3</sup> Marketed by HP as the Emulex LPe1205-HP 8Gb Fibre Channel Host Bus Adapter for c-Class BladeSystem (HP part number 456972-B21)

<sup>5</sup> In a vSphere environment, server resource limitations may reduce the level of support to 64 virtual ports. Fewer virtual ports are supported on Emulex 4Gb/s HBAs.



---

**Note**

HP also offers a c7000 enclosure, which can support up to 16 half-height blades.

---

Management of the enclosure can be achieved via [HP Onboard Administrator](#) module, which supports activities such as setup and configuration, access control, power and cooling management, and health and status monitoring.

### HP Virtual Connect

HP developed [Virtual Connect technology](#) to virtualize c-Class BladeSystem I/O, thus simplifying the configuration, administration and maintenance of server I/O connections.

Virtual Connect follows industry standards for defining Fibre Channel technologies, including NPIV, which allows a single physical port on an Emulex LPe1205-HP HBA to appear as multiple virtual ports, each having its own identity.

[Virtual Connect Enterprise Manager](#) (VCEM) software can be used to centralize the management of both Ethernet and Fibre Channel connectivity, becoming the single point of administration for Virtual Connect I/O interconnect modules.

### I/O interconnect modules

The HP c-Class BladeSystem enclosure supports a range of I/O interconnect modules at the server-edge, allowing you to configure the connectivity you need for a particular environment. For example, the HP Virtual Connect 8Gb 20-Port Fibre Channel Module for c-Class BladeSystem (8Gb/s Virtual Connect Fibre Channel module) interfaces the Emulex LPe1205 HBA with an 8Gb/s FC network. This module supports up to 16 internal paths, while providing four external 8Gb/s switches.

The 8Gb/s Virtual Connect Fibre Channel module provides enhanced support for server-side NPIV.



## HP ProLiant BL460c G7 server blade

The HP ProLiant [BL460c G7 server blade](#) delivers well-balanced performance, scalability and expandability, with features that include powerful Intel Xeon 5500 or 5600 series processors and a wide variety of I/O options, such as the Emulex LPe1205-HP HBA. It also supports HP's innovative Virtual Connect technology.

This server blade is ideal for heterogeneous data centers with workloads that include databases, virtualization and high performance computing applications.

## HP StorageWorks EVA

The HP StorageWorks Enterprise Virtual Array family is an enterprise class storage array system designed to aggregate and automate your array management tasks to manage storage capacity with less resources. The EVA is designed specifically for customers in the business critical, enterprise market place and is a scalable, highly available and reliable virtual array storage solution.

For more information on configuration best practices for HP StorageWorks EVA and VMware vSphere 4, please refer to the following whitepaper from HP:  
<http://h20195.www2.hp.com/V2/GetPDF.aspx/4AA1-2185ENW.pdf>

## Solution deployment overview

This document provides guidelines for deploying a robust, highly-available ESX environment featuring 8Gb/s Fibre Channel storage.

The following topics are included in this guide:

- **Deploying solution hardware:** Deploying the c3000 enclosure, Emulex LPe1205-HP HBA, BL460c G7 server blade and Virtual Connect I/O interconnect modules for server-side Fibre Channel and Ethernet connectivity
- **Ensuring interoperability:** Ensuring that firmware levels are appropriate
- **Configuring the BladeSystem enclosure:**
  - Configuring the HP c-Class BladeSystem domain
  - Mapping Fibre Channel and network connectivity within the enclosure
  - Creating a profile to apply to the HP ProLiant BL460c G7 server blade
  - Optional configuration activities such as fabric zoning and boot from SAN
- **Installing ESX 4.1:** Installation options
- **Managing the solution:** Installing OneCommand Manager



## Deploying solution hardware

Deploying the hardware required for this 8Gb/s Fibre Channel solution involves the following activities:

- Follow the “[HP BladeSystem c3000 Enclosure Setup and Installation Guide](#)” to rack mount the enclosure and provide appropriate power and cooling.
- Install an Emulex LPe1205-HP HBA in one of the mezzanine slots within the BL460c G7 server blade. Up to two of these cards can be installed in a staggered, double-decked configuration, allowing the blade to scale to as many as four 8Gb/s connections. For more information, refer to [Appendix A – The Emulex LPe1250-HP 8Gb/s Fibre Channel mezzanine card](#).

By design, no cable connections are made to the mezzanine card. Instead, Fibre Channel ports on the card connect electrically to the motherboard of the server blade and then to the backplane of the BladeSystem enclosure.

- Install the BL460c G7 server blade in one of the device bays in the c3000 enclosure, as shown in Figure 1.

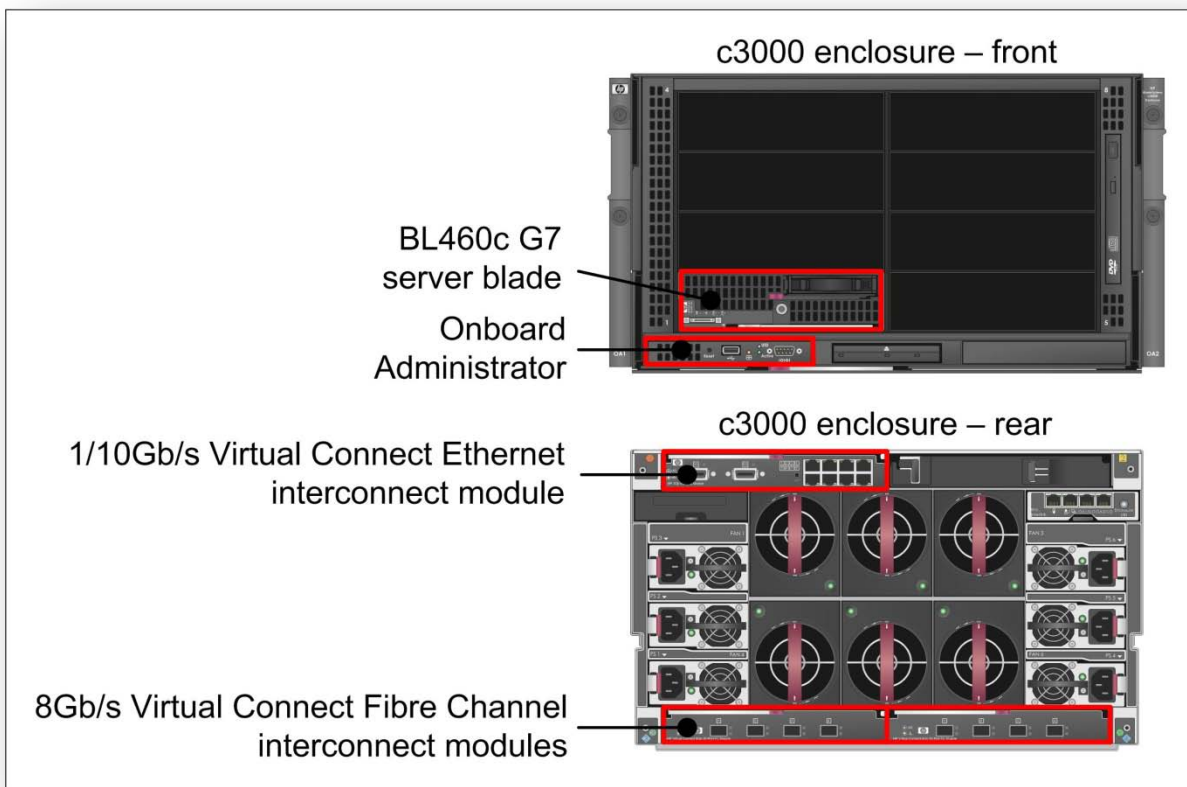

Figure 1 – A c3000 enclosure, featuring an HP ProLiant BL460c G7 server blade and various I/O interconnect modules, along with Onboard Administrator



- Install I/O interconnect modules in the c3000 enclosure, as shown in Figure 1.  
For this 8Gb/s Fibre Channel solution, the following modules are used:
  - **Fibre Channel:** To provide redundancy, two 8Gb/s Virtual Connect Fibre Channel modules are used to connect the backplane of the enclosure to the Fibre Channel fabric.
  - **Ethernet:** One HP 1/10Gb Virtual Connect Ethernet Module for c-Class BladeSystem (1/10Gb Ethernet module) is used to connect the BL460c G7 server blade to a high-speed Ethernet network for management purposes.

Before installing ESX 4.1 on the BL460c G7 server blade, you should first ensure that solution firmware is at least at minimum levels and then configure the HP c-Class BladeSystem infrastructure. Ideally you can also configure a fabric zone and boot from SAN capability.

## Ensuring interoperability

When creating "best of breed" multi-vendor solution such as this, interoperability is essential. Thus, not only must software and drivers be up-to-date but you must also ensure that the firmware running on the HP c-Class BladeSystem enclosure, HP ProLiant BL460c G7 server blade and I/O interconnect modules is at a particular level or higher.

Table 1 outlines the minimum levels for key solution components.

Table 1. Firmware levels

Component		Minimum level
BL460c G7 server blade	ROM (BIOS)	27 06/07/2010 127
Onboard Administrator	Firmware	3.20 August 25 2010
8Gb/s Virtual Connect Fibre Channel interconnect module	Firmware	1.41
1/10Gb/s Virtual Connect Ethernet interconnect module	Firmware	3.15
Emulex 8Gb/s Fibre Channel mezzanine card	Firmware	HP provides links to the latest drivers, firmware, boot code and documentation for Emulex LPe1205-HP HBAs at <a href="http://www8.hp.com/us/en/support-drivers.html">http://www8.hp.com/us/en/support-drivers.html</a> .

[Appendix B – Determining the firmware levels of HP components](#) explains how to determine the firmware levels of the HP components (Onboard Administrator, 8Gb/s Virtual Connect Fibre Channel module, 1/10Gb/s Virtual Connect Ethernet module and BL460c G7 BIOS).



## Updating firmware

The process for updating firmware in a BladeSystem environment is as follows:

1. Update Onboard Administrator
2. Update Virtual Connect firmware
3. Update server-specific firmware

For more information, visit the following HP sites:

- [Best practices for updating firmware](#)
- [Support and drivers](#)
- [Firmware compatibility chart](#)

After validating the interoperability of solution components, your next step is to configure the HP c-Class BladeSystem enclosure.

## Configuring the BladeSystem enclosure

This section demonstrates the tight integration between an Emulex LPe1205-HP HBA and the HP c-Class BladeSystem infrastructure, which makes it easy to map from the HBA to the server-edge. For the purposes of this discussion, you can think of each HBA as having an A port and a B port. Thus, if you were to fill this c3000 enclosure with eight blades, each equipped with two dual-port HBAs, there would be a total of 16 A-port connections (two per blade) and, similarly, 16 B-port connections. To provide redundancy for multipathing or failover, all 16 A-port connections can be mapped to one 8Gb/s Virtual Connect Fibre Channel interconnect module, while all 16 B-port connections can be mapped to a second interconnect module.

### Mapping Fibre Channel connections

Onboard Administrator combined with HP VCEM is used to map connections between ports on the Emulex LPe1205-HP HBA and the server-edge to provide custom access to external networks. However, these connections are not associated with particular devices; instead, they apply to bays within the HP c-Class BladeSystem enclosure – device bays that hold server blades and interconnect bays that support a range of I/O interconnect modules (as shown in Figure 2).

VCEM maintains a profile on each device bay that contains configuration information and lists all connections between the particular device bay and I/O interconnect modules. Having the profile tied to a bay rather than a specific device gives you the flexibility to replace a server blade with a similar system without having to perform any reconfiguration; the replacement simply assumes the existing profile.



Figure 2 – A c3000 enclosure, showing the numbering system used to identify the eight device bays for half-height server blades and four interconnect bays for I/O interconnect modules

Thus, Onboard Administrator can be used to view the connections required by this 8Gb/s Fibre Channel, which are as follows:

- Redundant Fibre Channel connectivity:
  - From Port A of the Emulex LPe1205-HP HBA to the 8Gb/s Virtual Connect Fibre Channel module in Interconnect Bay 3
  - From Port B of the Emulex LPe1205-HP HBA to the 8Gb/s Virtual Connect Fibre Channel module in Interconnect Bay 4
- Network uplink – From Port 1 of the BL460c G7 server blade's LAN on Motherboard (LOM) to the 1/10Gb/s Virtual Connect Ethernet module in Interconnect Bay 1



For example, Figure 3 shows Onboard Administrator's view of the port mapping for Interconnect Bay 3. Port 1 of the interconnect bay (8Gb/s Virtual Connect Fibre Channel module) has been mapped to Device Bay 1 (BL460c G7) – specifically, to Port 1 of Mezzanine Slot 2.

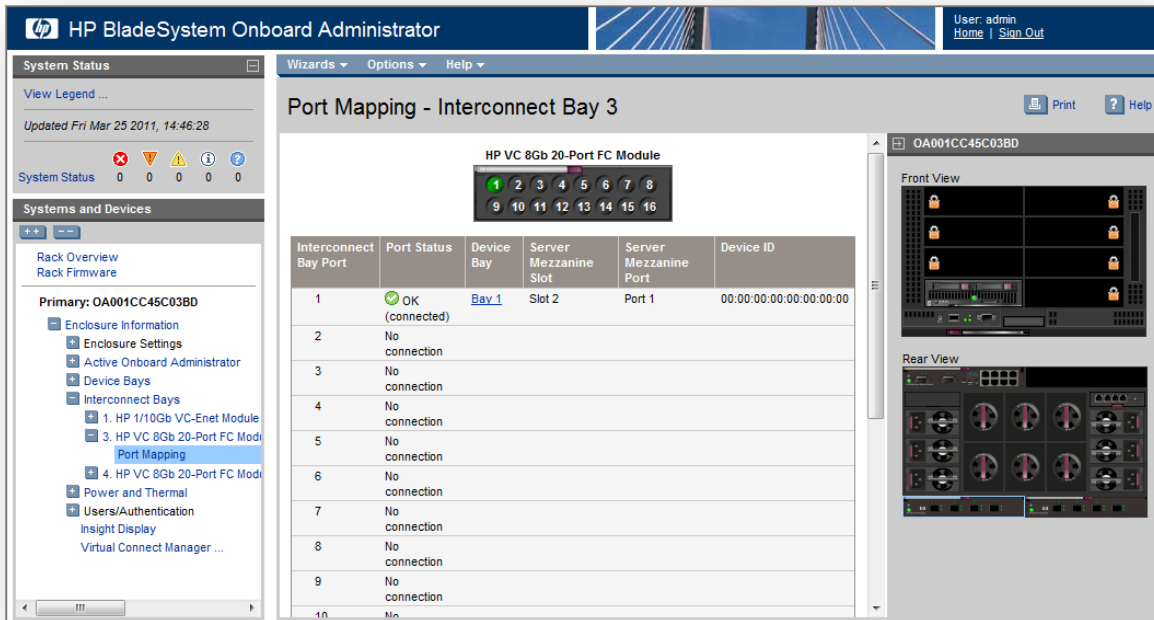

Figure 3 – Mapping a connection from an interconnect bay to a device bay

While you can map 16 Emulex LPe1205-HP HBA ports to each 8Gb/s Virtual Connect Fibre Channel interconnect module, these ports cannot each support 8Gb/s Fibre Channel simultaneously; the module only provides four 8Gb/s Fibre Channel connections to the fabric.

## Configuring the BladeSystem domain

To establish a foundation for setting up device bay profiles, you should first use VCEM to configure a domain for the BladeSystem enclosure.

The Domain Setup Wizard allows you to specify key settings for this 8Gb/s Fibre Channel solution, including the following:

- **Network:** Static, factory-default MAC addresses are used to identify the ports on the HP ProLiant BL460c G7 server blade's LOM. Static MAC addresses were used in the testing for simple deployment.
- **Storage:** Again for simplicity, static, factory-default worldwide names (WWNs) are used to identify the ports on the Emulex LPe1205-HP HBA, as shown in Figure 4. Since this option



ties the device bay to the particular HBA, some re-configuration would be required when you replace the server blade.

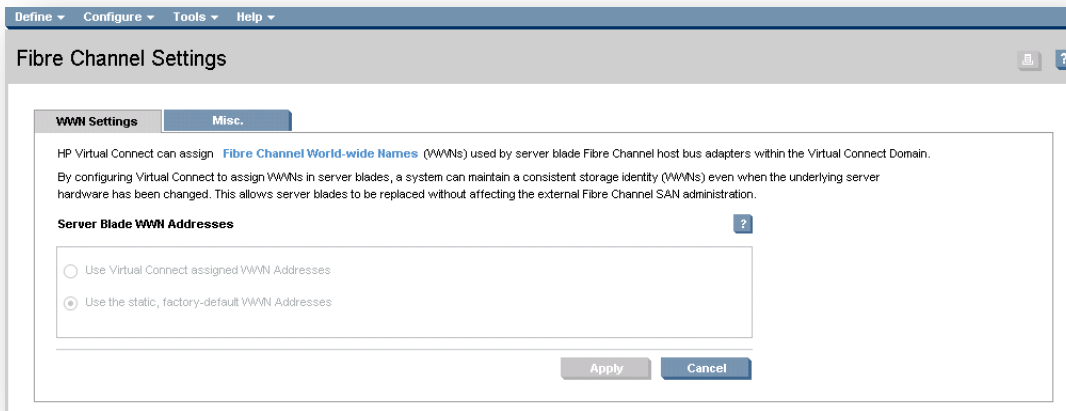

Figure 4 – Selecting the option to use static, factory-default WWNs to identify HBA ports

## Creating a server profile

After you have mapped the desired connectivity and set up the domain for the BladeSystem enclosure, you can use VCEM to create the appropriate profile for Device Bay 1.

---

### Note

A device bay profile is a logical grouping of attributes related to the connectivity specified for a particular server configuration.

---



As shown in Figure 5, the profile includes factory-default MAC and WWN addresses. The following networks have been configured:

- **Ethernet:** An uplink and a dedicated vMotion network
- **Fibre Channel:** Redundant 8Gb/s connections to Fibre Channel storage

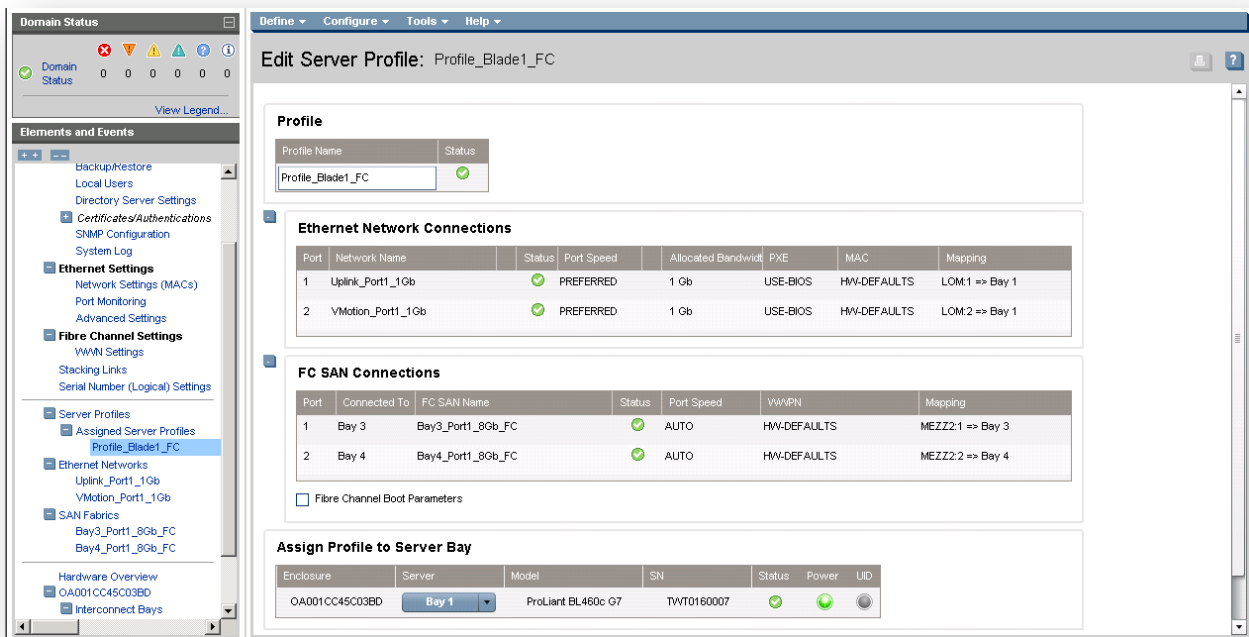

Figure 5 – Creating a server profile for Device Bay 1 which is used to house the HP ProLiant BL460c G7 server blade

## Completing the configuration

Optionally, you can complete the set-up of the BladeSystem enclosure with the following additional steps:

- Configuring zoning
- Configuring boot-from-SAN

Both of these options are outlined in subsequent sections.

When the BladeSystem configuration is complete and infrastructure switches have been set, you can install ESX 4.1 on the BL460c G7 server blade, as described in [Installing ESX 4.1](#).



## Zoning for VMware

It is important to implement fabric zoning in conjunction with this 8Gb/s Fibre Channel solution. For example, fabric zoning could be used to restrict access to storage arrays that are not allocated a particular ESX host server. In addition, zoning can protect LUNs on shared storage that is used by a pool of hosts.

In many ways, zoning is similar to LUN masking, a process that makes a LUN available to certain hosts and not others. The key difference is that LUN masking is usually achieved at the server- or storage processor-level, while zoning takes place at the fabric-level.

For more information on how to create zones, please refer to your fabric switch vendor documentation.

## Booting from SAN

In this 8Gb/s Fibre Channel solution, the HP ProLiant BL460c G7 server blade is configured to boot from SAN rather than a local disk. This approach has been widely adopted for a number of reasons, including the following:

- **High-availability:** Boot from SAN eliminates the reliance on a local hard drive, enabling the use case where a server blade becomes an appliance that can be removed and replaced without re-configuration. In addition, RAID technology can accommodate a disk failure with no impact on system availability
- **High performance:** Using a Fibre Channel disk is faster than using a local drive. For a local ATA drive, the transfer rate is around 400Mb/s; however, since Fibre Channel communications are offloaded to hardware on the mezzanine card, the connection to a Fibre Channel target may be 8Gb/s, much faster than direct-attached iSCSI or SATA.
- **Centralized image management:** Since OS images are stored on the SAN, maintenance and upgrades can be managed from a central point, eliminating the need to be present at individual servers.
- **Disaster recovery:** OS images can be constantly mirrored both locally and to remote sites. In a disaster recovery situation, the server can be quickly redirected to a remote OS boot image with no data loss. In addition, in the event of a failure, a replacement server can be targeted to boot from the desired OS image.

Boot from SAN is supported on the Emulex LPe1205-HP HBA via boot code that can be stored on-board. At boot time, this code points the host server to a specified LUN rather than a partition on the local disk.



The HBA gives you the option to boot from up to 16 Fibre Channel targets or LUNs. If the first target is unavailable, then the HBA attempts to boot from the second, and so on. This feature is useful in an environment where multiple systems are booting from the same storage pool. Once the connection between a server and a particular FC target has been established, it can be locked.

## Configuring boot from SAN

Configuring the BL460c G7 server blade to boot from SAN is a two-stage process that involves the following activities:

- Provisioning the target LUN and mapping it to the Emulex LPe1205-HP HBA
- Enabling the BIOS on the HBA, as described in the [VMware vSphere Online Library](#)

---

### Note

Verify that your storage array supports boot from SAN.

You may need to configure a host mode setting on array. For recommended settings, contact your storage vendor.

Verify that VMware supports the array by reviewing the [VMware Compatibility Guide](#).

---



Figure 6 shows one of the steps from this procedure in which the Adapter BIOS is enabled.

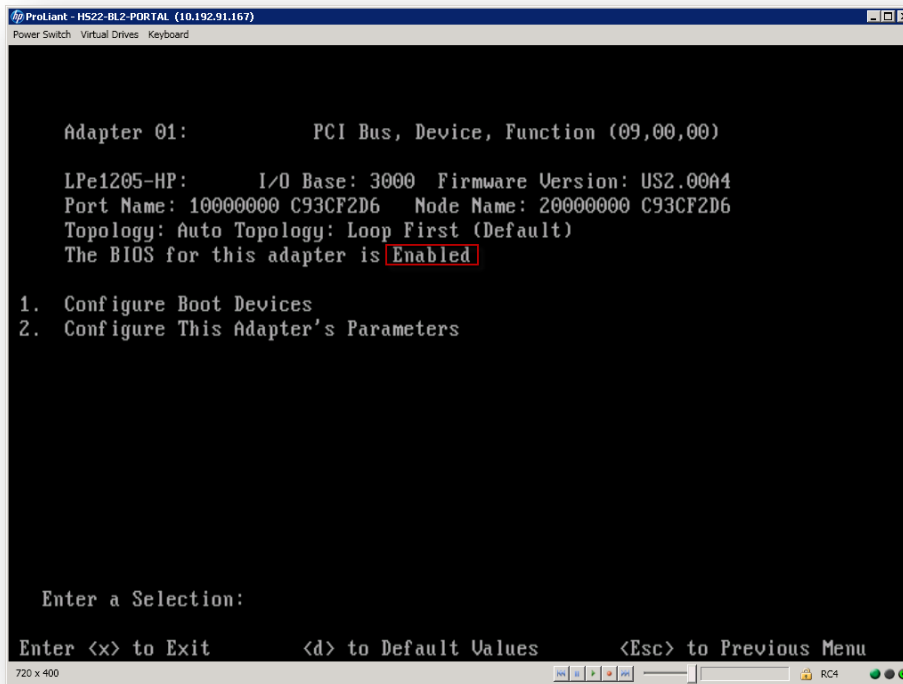

Figure 6 – Ensuring that the boot code (BIOS) is running on the HBA

## Installing ESX

Installing ESX 4.1 (and later) on an HP ProLiant server blade is no different than on a rack-mounted server, with one significant exception – with a server blade, you should first pre-configure VCEM with appropriate device bay profiles. Thus, for this 8Gb/s Fibre Channel solution, a profile is applied to the device bay housing the BL460c G7 server blade.

### Installation methods

After the firmware for solution hardware has been updated, you have a range of options for installing ESX 4.1, including the following:

- DVD
- ISO image
- HP USB
- Preboot Execution Environment (PXE) boot
- Automated install (for example, by HP Insight Rapid Deployment software)



## Performing the installation

For this 8Gb/s Fibre Channel solution, an ISO image was mounted through the HP ProLiant BL460c G7 server blade's Integrated Lights-Out (iLO) management port.

Since the driver for the Emulex LPe1205-HP HBA is in-box with ESX 4.1, there is no need to install an additional Fibre Channel driver for this adapter only updates. However, a driver – [VMware ESX/ESXi 4.x Driver CD for Emulex BladeEngine 10Gb Ethernet Controller](#) – is required to support NIC ports provided by the server blade's LOM.

---

### Note

The LOM is an HP NC553i Dual Port Flex Fabric 10Gb Adapter

---

For information on best practices for installing ESX 4.1, refer to the [VMware Knowledge Base Article #1022101](#).

## Managing the solution

Like vSphere Client, which can be used to administer a local ESX host or connect to a vCenter server where all servers in a vSphere infrastructure are managed, Emulex's OneCommand Manager application provides centralized management of Emulex adapters in physical and virtual server deployments. IT administrators can leverage OneCommand Manager's graphical user interface (GUI) or fully scriptable command line user interface (CLI) within their environment, providing powerful adapter provisioning and diagnostic capabilities which help to increase administration efficiency and business agility.

To further streamline management in VMware ESX and ESXi environments, IT administrators can deploy OneCommand Manager for VMware vCenter. This plug-in enables comprehensive control of Emulex adapters directly from VMware's vCenter management console, helping to unify and simplify virtualization management.

## Key functionality

Key functionality offered by OneCommand Manager includes:

- Unified platform for management of Emulex fabric (Fibre Channel HBA) and network (iSCSI adapter, FCoE UCNA, NIC) connectivity solutions
- Centralized real-time discovery, monitoring and administration of Emulex fabric and network connectivity adapters and connected devices
- GUI and scriptable CLI options
- Cross-platform solution with broad operating system (OS) and hypervisor
- Online "Boot-from-SAN" capability



- Automated, batch driver and firmware update capabilities
- Extensive diagnostic and troubleshooting capabilities
- Web-launch capability for increase management access flexibility
- Memory dump for de-bug purposes<sup>6</sup>
- Change Parameters Permanently or Temporarily
- Web-launch capability for increase management access flexibility

---

**Note**

For more information on the features and benefits of OneCommand Manager, refer to <http://www.emulex.com/products/management-software/device-management/onecommand-manager/overview.html>.

---

Figure 7 shows a typical OneCommand Manager adapter view from the host.

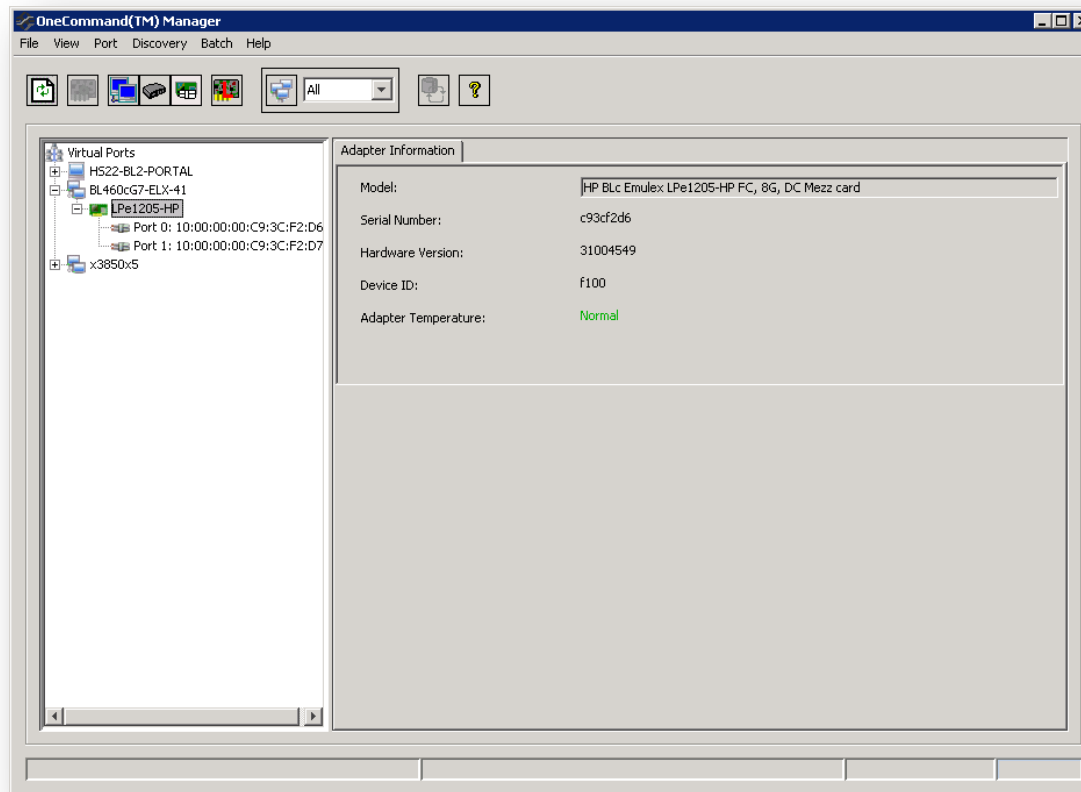

Figure 7: OneCommand Manager view showing the HP ProLiant BL460c G7 server blade configured with an Emulex LPe1205-HP HBA

---

<sup>6</sup> You can send the file to Emulex for further analysis. For example, Emulex can determine the topology you are using, the number of LUNs, the most recent commands and resulting status.



## Installing OneCommand Manager

OneCommand is [available](#) free-of-charge from Emulex as part of the **UCNA and HBA Applications Kit**<sup>7</sup>. Follow the steps outlined below to install the Applications Kit, which is provided as an RPM package:

1. From a management workstation, download the Applications Kit and store it in a temporary directory.
2. Use a tool such as WinSCP (an FTP client) to move the .rpm file to the ESX host.
3. Store the .rpm file in a **/tmp** directory.
4. Log on to the ESX host using a secure shell tool such as PuTTY.
5. Run the following command, as shown in Figure 8:

```
rpm -U elxocmcore-esx41-5.1.42.7-1.x86_64.rpm
```

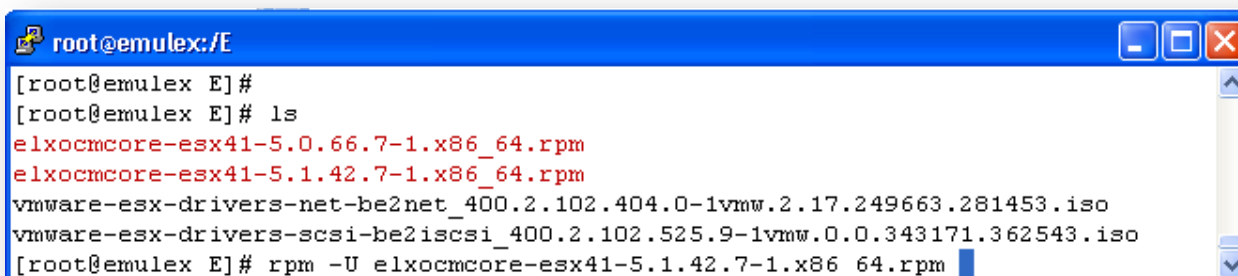

```
root@emulex:/E
[root@emulex E]#
[root@emulex E]# ls
elxocmcore-esx41-5.0.66.7-1.x86_64.rpm
elxocmcore-esx41-5.1.42.7-1.x86_64.rpm
vmware-esx-drivers-net-be2net_400.2.102.404.0-1vmw.2.17.249663.281453.iso
vmware-esx-drivers-scsi-be2iscsi_400.2.102.525.9-1vmw.0.0.343171.362543.iso
[root@emulex E]# rpm -U elxocmcore-esx41-5.1.42.7-1.x86_64.rpm
```

Figure 8. Installing OneCommand Manager

To allow OneCommand Manager to communicate with other ESX hosts in your environment, you should open a firewall port, as follows:

1. Log on to each ESX host's service console.
2. Run the following command:  
**esxcfg-firewall --openPort 23333,tcp,in,onecommand**
3. Run the following command:  
**esxcfg-firewall --openPort 23333,tcp,out,onecommand**
4. To verify that the port is open, run the following command:  
**esxcfg-firewall -q**

TCP port 23333 should now be open.

<sup>7</sup> Installing the Applications Kit also deploys a Common Information Model (CIM) provider for Fibre Channel.



## Summary

This Implementer's Guide provides a baseline for configuring a robust, highly-available ESX environment with 8Gb/s Fibre Channel storage on certified, tested HP c-Class BladeSystem hardware. With Emulex, the process for installing and managing a rich I/O ESX environment is simple. Since the driver for the Emulex LPe1250-HP HBA is in-box, there is no need to create or post-install a driver. The unique OneCommand Manager for VMware vCenter gives you native, centralized management of all I/O adapters for maximum availability, flexibility, and performance.

Achieving an optimal configuration requires some expertise with HP ProLiant servers, HP BladeSystem enclosures and Virtual Connect technology. Thus, you should ideally implement a proof of concept environment before placing such a configuration into production.



## Appendix A – The Emulex LPe1250-HP 8Gb/s Fibre Channel mezzanine card (HP part number 456972-B21)



The Emulex LightPulse LPe1205-HP Fibre Channel adapter (HP part number 456972-B21) used in this test project is a dual-port mezzanine card designed for HP ProLiant G7 server blades.

Streamlined installation and management, unrivaled scalability, and industry-leading virtualization support make these HBAs ideal I/O solutions for enterprise, mixed operating system and virtualized environments.

The highly integrated processor design minimizes onboard components to improve host performance and efficiency, while advanced error-checking features ensure the integrity of block data as it traverses the SAN. The firmware-based architecture of this card enables feature and performance upgrades without costly hardware changes.

### Key features

- Support for 8Gb/s, 4Gb/s and 2Gb/s FC devices
- Comprehensive virtualization capabilities, including support for N-Port Identification Virtualization (NPIV) and integration with HP Virtual Connect
- Host to Fabric FC-SP authentication
- Common driver model allows a single driver to support all Emulex LPe1205 HBAs on a particular operating system
- Easy deployment of new firmware with minimal server reboots
- Efficient centralized administration via powerful management tools

### Key benefits

- Provides superior performance for the enterprise
- Integrates seamlessly into existing SANs
- Supports IT server consolidation and energy-conservation initiatives
- Supports the application of SAN best practices, tools and processes in virtual server deployments
- Protects sensitive data from unauthorized access
- Assures data availability and data integrity



- Improves IT staff productivity through simplified deployment and management
- Reduces hardware acquisition, power, cooling and management costs

## Installing a mezzanine card

Figure A-1 shows the physical locations of the two mezzanine card slots in a HP ProLiant BL460c G7 server blade. There are upper and lower slots so that HBAs can be installed in double-decked fashion.



Figure A-1 – Showing the mezzanine card slots (gold-colored) in a BL460c G7 server blade

In this example, an HBA is being installed in the lower slot, as shown in Figure A-2.



Figure A-2 – Installing an HBA



## Appendix B – Determining the firmware levels of HP components

Onboard Administrator can be used to determine the firmware levels of the following HP hardware components used in the Fibre Channel vMotion solution:

- Onboard Administrator
- 8Gb/s Virtual Connect Fibre Channel module
- 1/10Gb/s Virtual Connect Ethernet module
- BL460c G7 server blade

### Onboard Administrator

Click on the desired device in the Onboard Administrator display. In this example, it is Onboard Administrator itself. Check the **Status and Information** tab, as shown in Figure B-1.

The screenshot shows the HP BladeSystem Onboard Administrator interface. The main content area displays the 'Active Onboard Administrator' configuration for device OA001CC45C03BD. The 'Status and Information' tab is active, showing the following details:

Status and Information	
Status	OK
Role	Active
Bay Number	1
Temperature	25°C / 77°F
Caution Threshold	75°C / 167°F
Critical Threshold	80°C / 176°F

Information	
Device Name	BladeSystem c3000 Onboard Administrator
Manufacturer	HP
Firmware Version	3.20 Aug 25 2010
Hardware Version	B0
Part Number	448589-B21
Spare Part Number	441832-001
Serial Number	P30590C9VV10XS

Diagnostic Information	
Device Identification Data	OK

The 'Firmware Version' field is highlighted with a red border. The interface also includes a 'System Status' sidebar on the left and 'Front View' and 'Rear View' images on the right.

Figure B-1 – The firmware level of Onboard Administrator is 3.20 August 25 2010



## 8Gb/s Virtual Connect FC module

Double-click on Interconnect Bay 3 (or 4) in the Onboard Administrator display. Check the **Information** tab, as shown in Figure B-2.

The screenshot displays the HP BladeSystem Onboard Administrator interface. The main window is titled "Interconnect Bay Information - Bay 3". The "Information" tab is active, showing the following details:

Information	
Product Name	HP VC 8Gb 20-Port FC Module
Management IP Address	10.192.91.170
Management URL	
User Assigned Name	VCFCN8010Z09V
Part Number	572018-B21
Spare Part Number	572216-001
Serial Number	CN8010Z09V
Type	Fibre Channel
Manufacturer	HP
Temperature Sensor	Present
Firmware Version	1.41

Below the information table, the "Connectivity" section shows the following status:

Connectivity	
JS2 Connector	Absent
Internal Ethernet Interface to OA	Present
Internal Ethernet Route to OA	Enabled
Internal Serial Interface to OA	Absent
Internal Serial Route to OA	Enabled
External Serial Port Interface	Absent
External Ethernet Interface	Absent

The interface also shows a "Front View" and "Rear View" of the hardware components on the right side.

Figure B-2 – The firmware level of the 8Gb/s Virtual Connect FC module is 1.41



## 1/10Gb/s Virtual Connect Ethernet module

Double-click on Interconnect Bay 1 in the Onboard Administrator display. Check the **Information** tab, as shown in Figure B-3.

The screenshot displays the HP BladeSystem Onboard Administrator interface. The main window is titled "Interconnect Bay Information - Bay 1". The "Information" tab is active, showing a table of details for the HP 1/10Gb VC-Enet Module. The "Firmware Version" is highlighted with a red box and is listed as 3.15. The interface also includes a left-hand navigation pane, a top status bar, and a right-hand view of the module's front and rear panels.

Information	
Product Name	HP 1/10Gb VC-Enet Module
Management IP Address	10.192.91.168
Management URL	http://10.192.91.168/
User Assigned Name	
Part Number	399593-B22
Spare Part Number	399725-001
Serial Number	TW2734013F
Type	Ethernet
Manufacturer	HP
Temperature Sensor	Present
<b>Firmware Version</b>	<b>3.15</b>

Connectivity	
JS2 Connector	Absent
Internal Ethernet Interface to OA	Present
Internal Ethernet Route to OA	Enabled
Internal Serial Interface to OA	Present
Internal Serial Route to OA	Enabled
External Serial Port Interface	Absent
External Ethernet Interface	Absent
Serial Port Baud Rate	115200

Figure B-3 – The firmware level of the 1/10Gb/s Virtual Connect Ethernet module is 3.15



## BL460c G7 server blade

Double-click on Device Bay 1 in the Onboard Administrator display. Check the **Information** tab, as shown in Figure B-4.

The screenshot displays the HP BladeSystem Onboard Administrator interface. The main window is titled "Device Bay Information - ProLiant BL460c G7 (Bay 1)". The "Information" tab is selected, showing the following details:

Device Information	
Blade Type	Server Blade
Manufacturer	HP
Product Name	ProLiant BL460c G7
Part Number	XXXXXX-XXX
System Board Spare Part Number	605659-001
Serial Number	TWT0160007
UUID	58585858-5858-5754-5430-313630303037
BIOS Asset Tag	
Server Name	WIN-5E0CYX9EJHH
ROM Version	127 06/07/2010

Server NIC Information			
Ethernet MAC Port 1-a	78:E7:D1:FA:9A:B8		
iSCSI/FCoE MAC Port 1-b	78:E7:D1:FA:9A:B9		
FCoE WWN Port 1-b	10:00:78:E7:D1:FA:9A:B9		
Ethernet MAC Port 2-a	78:E7:D1:FA:9A:BC		
iSCSI/FCoE MAC Port 2-b	78:E7:D1:FA:9A:BD		
FCoE WWN Port 2-b	10:00:78:E7:D1:FA:9A:BD		
Port: iLO	00:23:7D:EF:40:EB		

Mezzanine Card Information			
Mezzanine Slot	Mezzanine Device	Mezzanine Device Port	Device ID
2	Emulex LPe1205-HP RCh FC HRA		

The interface also shows a "Front View" and "Rear View" of the server blade, and a "Systems and Devices" sidebar on the left.

Figure B-4 – The ROM level of the BL460c G7 server blade is 127 06/07/2010



## For more information

Emulex Fibre Channel HBAs	<a href="http://www.emulex.com/products/fibre-channel-hbas.html">http://www.emulex.com/products/fibre-channel-hbas.html</a>
Emulex LightPulse LPe1205-HP Fibre Channel mezzanine card	<a href="http://www.emulex.com/products/host-bus-adapters/hp-branded/lightpulse-lpe1205-hp/overview.html">http://www.emulex.com/products/host-bus-adapters/hp-branded/lightpulse-lpe1205-hp/overview.html</a>
Emulex OneCommand Manager	<a href="http://www.emulex.com/products/management-software/device-management/onecommand-manager/overview.html">http://www.emulex.com/products/management-software/device-management/onecommand-manager/overview.html</a>
HP BladeSystem	<a href="http://h18004.www1.hp.com/products/blades/index.html">http://h18004.www1.hp.com/products/blades/index.html</a>
HP Virtual Connect Technology	<a href="http://h18004.www1.hp.com/products/blades/virtualconnect/index.html">http://h18004.www1.hp.com/products/blades/virtualconnect/index.html</a>
HP FlexFabric	<a href="http://www8.hp.com/us/en/solutions/solutions-detail.html?compURI=tcm:245-790866&amp;pageTitle=FlexFabric-Network">http://www8.hp.com/us/en/solutions/solutions-detail.html?compURI=tcm:245-790866&amp;pageTitle=FlexFabric-Network</a>
VMware vSphere	<a href="http://www.vmware.com/products/vsphere/">http://www.vmware.com/products/vsphere/</a>
VMware vSphere documentation	<a href="http://www.vmware.com/support/pubs/vs_pubs.html">http://www.vmware.com/support/pubs/vs_pubs.html</a>

## Solution Implementer's Series is available at the Implementer's Lab



**Solution  
Implementer's  
Series™**

Visit the Implementer's Lab at [www.ImplementersLab.com](http://www.ImplementersLab.com). This site is a one-stop online technical resource responding to the most relevant network I/O implementation best practices for deploying today's leading storage and server solutions. Here, you'll find other Solution Implementer's Series of technical how-to-guides, the Implementer's Lab blog, the Implementer's Lab online discussion forum and technical training videos and webcasts.

To help us improve our documents, please provide feedback at [ImplementersLab@emulex.com](mailto:ImplementersLab@emulex.com).

*VMware is a registered trademark of VMware Corporation.  
LightPulse is a registered trademark of Emulex Corporation.  
OneCommand is a trademark of Emulex Corporation.*



[www.emulex.com](http://www.emulex.com)

World Headquarters 3333 Susan Street, Costa Mesa, California 92626 +1 714 662 5600  
Bangalore, India +91 80 40156789 | Beijing, China +86 10 68499547  
Dublin, Ireland +35 3 (0)1 652 1700 | Munich, Germany +49 (0) 89 97007 177  
Paris, France +33 (0) 158 580 022 | Tokyo, Japan +81 3 5322 1348  
Wokingham, United Kingdom +44 (0) 118 977 2929